



Systemtelefon Analog
HTA 711-01

**Analogue System
Telephone**
HTA 711-01

**Téléphone système
analogique**
HTA 711-01

Citofono analogico
HTA 711-01

**Systemtelefon
Analog**
HTA 711-01

Systemtelefon Analog
HTA 711-01

Systemtelefon Analog
HTA 711-01

**Systémový analogový
telefon**
HTA 711-01

Installation

Application

The analogue system telephone HTA 711-01 with built-in electronic call signal encoder via a separate loudspeaker and audio privacy device can be used in systems with or without audio privacy function as a substitute for system telephone HT 611-01. With call generator 3-tone-chime, alpha- and continuous tone. Activation by potential "b" through terminal "G" for 3-tone-chime, 7" for alpha- and "10" for continuous tones (story call) respectively. **Only the alpha- and continuous tones can be generated if (terminal) potential "b" is not used.** The call signal volume can be adjusted for all types of call.

Fields of application:

- Door telephony without audio privacy function, AS-2/53-.. and predecessor as well as video AS-6/2-53a-...
- Door telephony with audio privacy function, AS-2/63-.. and predecessor as well as video AS-6/2-63a-...
- Door telephony using wire saving technology, without audio privacy device AS-2/58-.. and AS-2/59-... with TLM 521-... as well as video AS-6/2-58-... .

The HTA 711-... is configured for surface wall mounting. A 55 mm switch box must be provided under the HTA 711-... Using the various accessories (ZUR 711-0... / 2T) it is also possible to install the HTA 711- in a flush-mount or table-top version.

Important:

With the AS-2/63-., the AS-2/58-.. and the AS-2/59-., note the differences in installation as against the HT 611-01! **See the comparison.**

Application in other external circuits is not possible!

Mounting

- 1 Open the system telephone
- 2 When mounting with socket fixture, the socket fixture must be removed to fasten the housing floor. Then replace the circuit board.

3 After installing and connecting the system telephone, plug in the attached spring cord to the circuit board with the long end as shown, and coil around the notches provided. Finally, plug in the short end to the handset.

4 (no illustration)

The door release button of the system telephone HTA 711-... is a **floating contact**. Terminal **6.1** must accordingly be **bridged** with terminal **c** at the system telephone.

5 Comparison with previous Siedle in-house telephones in circuits without audio privacy function AS-2/53-...

* Connection for storey call button.

6 Comparison with previous Siedle in-house telephones in circuits with audio privacy function AS-2/63-...

* Insert a jumper between terminal "8" / "c" and "6.1"

** To prevent feedback, insert an appr. 220 Ω resistor in series with terminal 11.

*** This ZM can only be operated with NG 402-02.

**** If there is a control unit LN 1983 a/b available, this must be replaced by the UG 502 with ZUG 502-01.

7 Comparison when using wire-saving system (2+n) in accordance with AS-2/58-... No call differentiation possible for storey calls.

8 Comparison when using wire-saving system (1+n) in accordance with AS-2/59b-... No call differentiation possible for storey calls.

Note!

If the HTA 711-... when used in an "existing system" with HT 611-..., HT 511-..., HT401a-01 etc. is not sufficiently loud, the system must be checked and the telephones connected as follows: Terminal "9" of the HTs at terminal "9" of the line rectifier **and** terminal "+" of the door loudspeaker at terminal "+" of the line rectifier.

Specifications

- Audio privacy function
- Call current max. 200 mA
- Call volume max. 83 dB(A)
- Light button floating contact, contact load 24 V/1A
- Door release button floating contact, contact load 24 V/1A

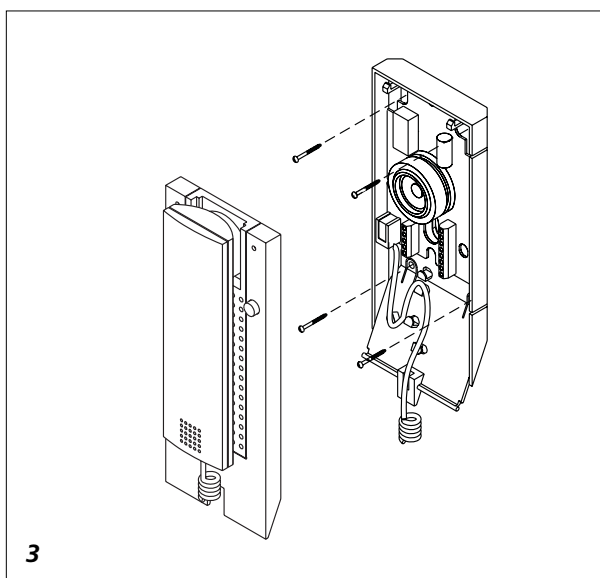
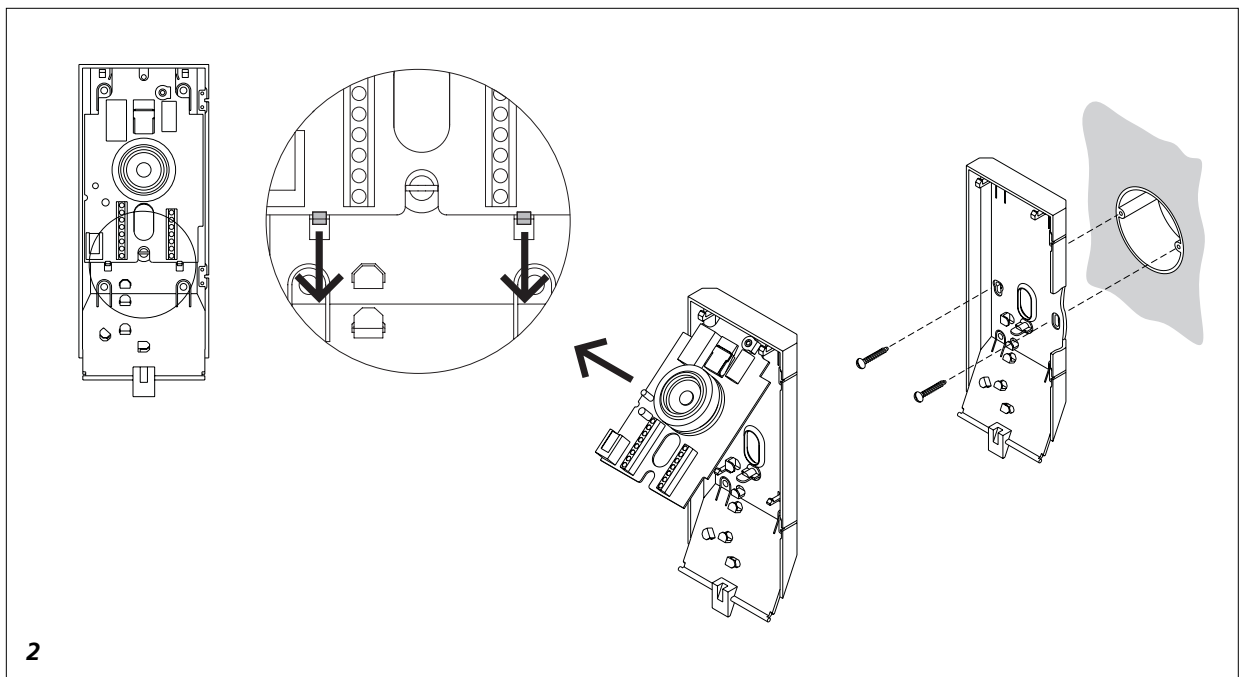
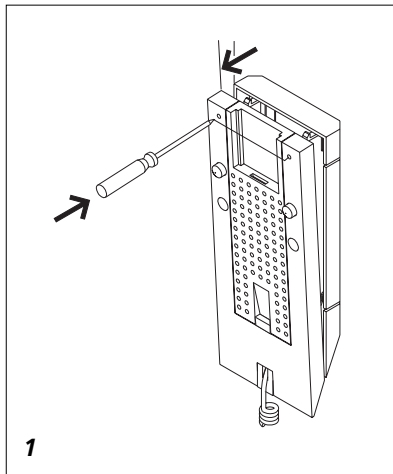

Geräte austauschen

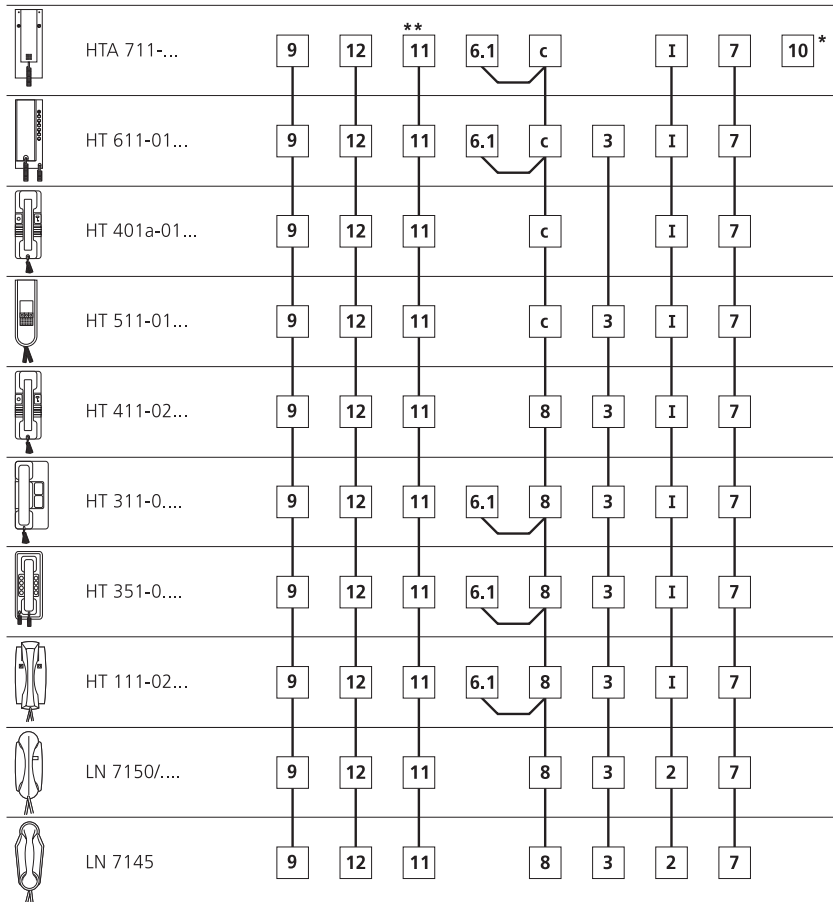

5

Geräte austauschen

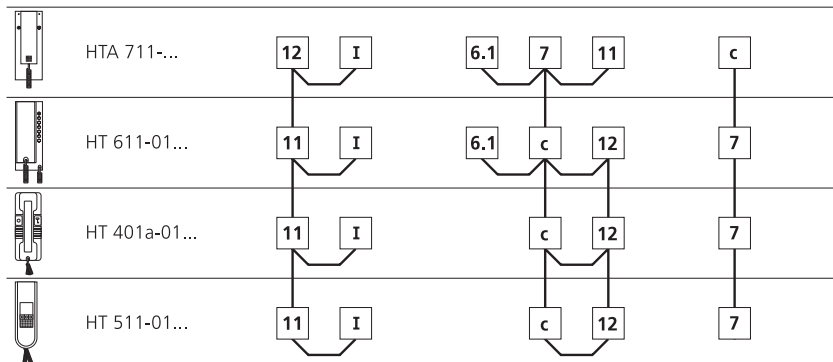

7

Geräte austauschen

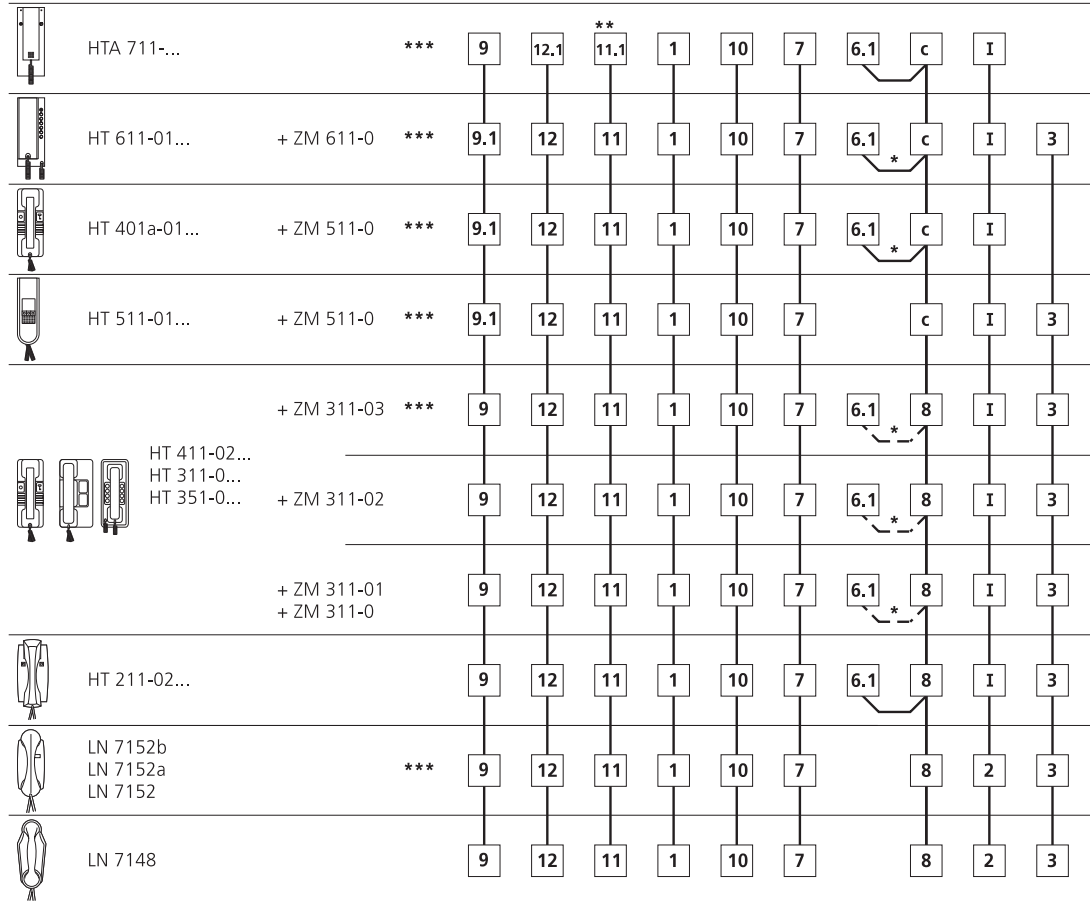

6

Geräte austauschen

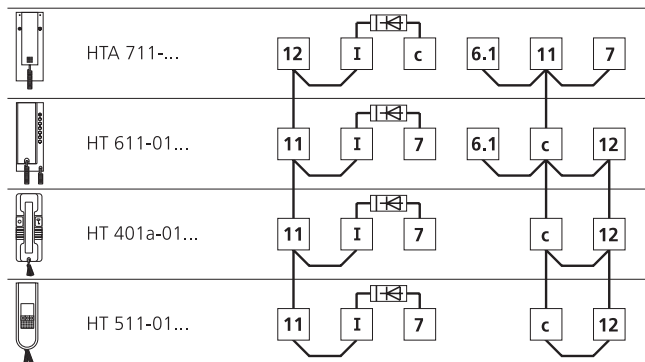

8